

A

B

C

D

E

F

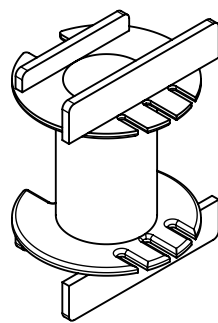
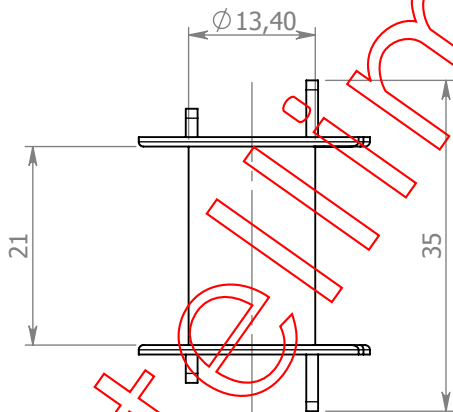
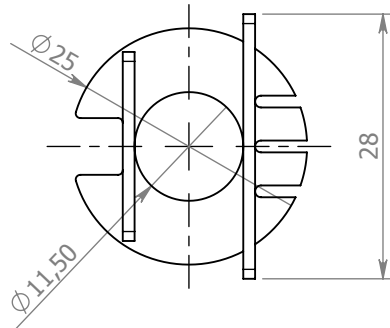

www.fratellimotta.it

		Via 4 Novembre, 44 20050 Ronco Briantino -MI- Tel. 039 6079022 Fax. 039 6079705		MODIFICHE:																
				REV.	DATA	APPR.	DESCRIZIONE													
<table border="1" style="width: 100%; border-collapse: collapse;"> <tr> <th>NAME</th> <th>SIGNATURE</th> <th>DATE</th> </tr> <tr> <td>DIS. Motta A.</td> <td></td> <td>20/05/09</td> </tr> <tr> <td>CONTR. Motta A.</td> <td></td> <td>20/05/09</td> </tr> <tr> <td>APPR. Motta A.</td> <td></td> <td>20/05/09</td> </tr> <tr> <td>MOD.</td> <td></td> <td></td> </tr> </table>		NAME	SIGNATURE	DATE	DIS. Motta A.		20/05/09	CONTR. Motta A.		20/05/09	APPR. Motta A.		20/05/09	MOD.					<b>CODICE:</b>  <b>CT 104</b>	
NAME	SIGNATURE	DATE																		
DIS. Motta A.		20/05/09																		
CONTR. Motta A.		20/05/09																		
APPR. Motta A.		20/05/09																		
MOD.																				
Disegno di proprietà di F.lli MOTTA s.r.l. sono vietati tutti gli utilizzi se non accompagnati da autorizzazione scritta.		MATERIALE: PA66 G25 V0 MATERIALE PINS:		<table border="1" style="width: 100%; border-collapse: collapse;"> <tr> <td>DIS.</td> <td style="text-align: center;"><b>Per ferrite ETD 34</b></td> <td>REV.</td> <td style="text-align: center;"><b>A4</b></td> </tr> <tr> <td>PESO:</td> <td></td> <td>SCALA:</td> <td style="text-align: center;"><b>1:1</b></td> </tr> </table>		DIS.	<b>Per ferrite ETD 34</b>	REV.	<b>A4</b>	PESO:		SCALA:	<b>1:1</b>							
DIS.	<b>Per ferrite ETD 34</b>	REV.	<b>A4</b>																	
PESO:		SCALA:	<b>1:1</b>																	